

# ASP-631 P-F-M version



The grinder is designed for sharpening according to the following configurations:

- P** – sharpening circular saws with diameters from 100 mm to 630 mm (optionally 800 mm)
- F** – sharpening straight cutters up to 250 mm in diameter
- PF** – sharpening saws and cutters
- FM** – sharpening straight cutters and vee joints (finger joints)
- PFM** – sharpening straight saws and cutters and vee joints (finger joints)



# ASP-631 PFM

## Features of the ASP-631 PFM

- An all-purpose device for automatic sharpening of saws and cutters
- An intuitive and clear control system with a graphical user interface
- Minimum machine operating costs
- Robust and well thought-out design

## Outcome

- The perfect combination of precision and performance
- The highest price/quality ratio.



# Design Assumptions

An all-purpose machine available in several model versions

- P – sharpening circular saws with diameters from 100 mm to 630 mm (optionally 800 mm)
- F – sharpening straight cutters up to 250 mm in diameter
- PF – sharpening saws and cutters
- FM – sharpening straight cutters and vee joints (finger joints)
- PFM – sharpening straight saws and cutters and vee joints (finger joints)

- Robust and compact design
- No hydraulic systems
- Using highest quality components

Polish engineering solutions have resulted in the creation of functional and economical grinders of the ASP-631 series, which are an obvious choice for carpentry workshops, sawmills, and furniture manufacturers.



Sharpening circular saws



Sharpening straight cutters



Sharpening cutters for finger joints

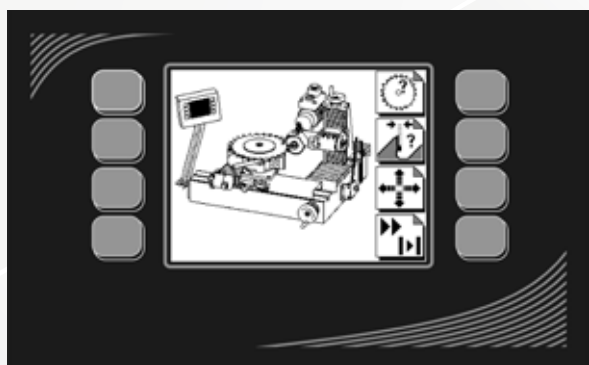
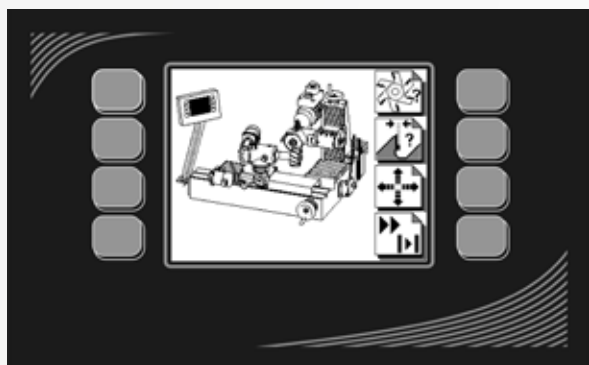

Intuitive control system

# ASP-631, P version

## Description and application

The ASP-631 P version is a machine designed for the automatic sharpening of the clearance surface and tooth face of circular saws up to 630 mm in diameter (optionally 800 mm). It enables the sharpening of saws with flat, alternate bevel, one-sided bevel and trapezoidal teeth. With the help of accessories, you can expand the machine's capabilities with wet grinding, sharpening of milling cutters, sharpening of curved teeth, knives, lightweight heads, and chip breaker saws featuring a concave face

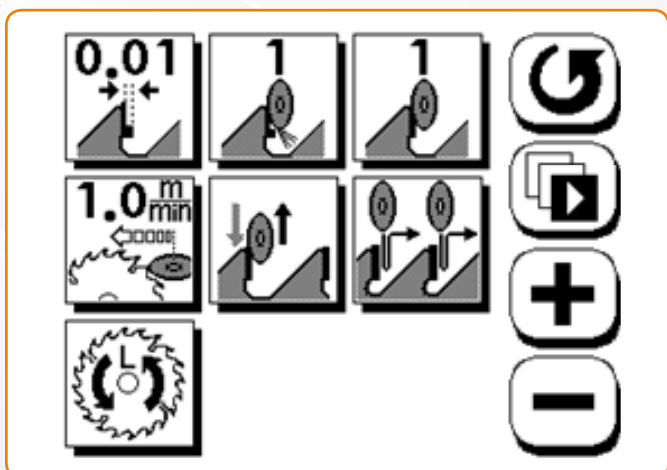

## Advantages

- Sharpening saws with a negative and positive faces
- Using of support and pressure disks to stabilise the saw
- Internal memory for saving saw parameters
- Electronically controlled tooth pitch
- Robust and compact design
- Sharpening milling cutters (optional)
- Selecting the tool sharpening programme with or without moving the tool away from the grinding wheel during travel
- Controller functions to customise the controller's parameters to individual user requirements

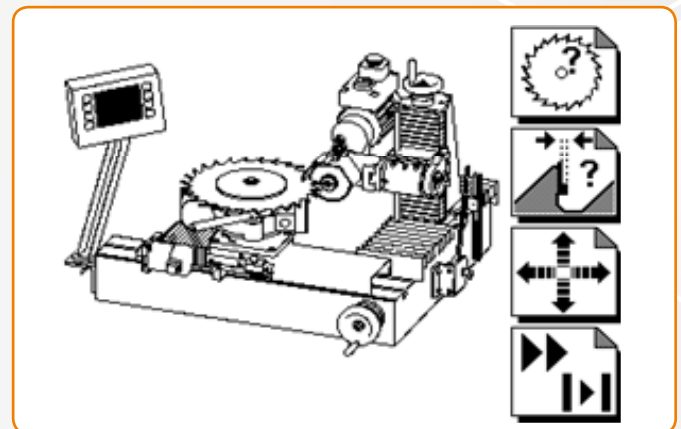

# ASP-631 F version

## Description and application

The ASP-631 F version is a machine designed for the automatic sharpening of the clearance surface and face of cutters up to 250 mm in diameter. The grinder is designed, among others, for sharpening disc milling cutters, slotting mills, angle cutters and taps. With the help of accessories, you can expand the machine's capabilities with wet grinding, sharpening of milling cutters for vee joints, sharpening of saws, sharpening of curved teeth, knives, lightweight heads, and chip breaker saws with a concave face.

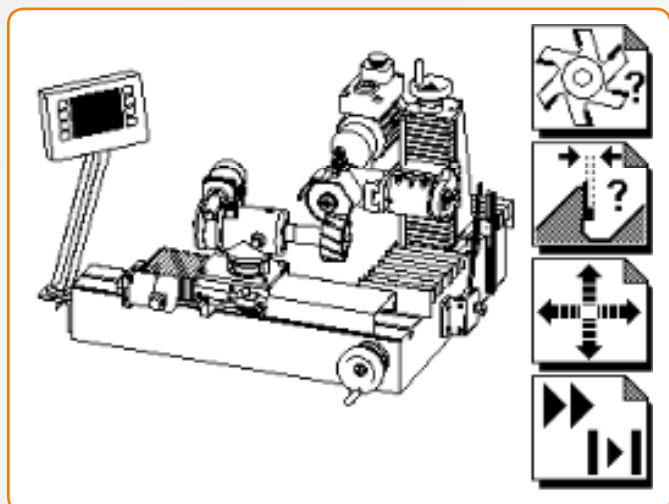

## Advantages

- Internal memory for saving cutter parameters
- Electronically controlled tooth pitch
- Robust and compact design
- Sharpening circular saws (optionally)
- Selecting the tool sharpening programme with or without moving the tool away from the grinding wheel during travel
- Controller functions to customise the controller's parameters to individual user requirements

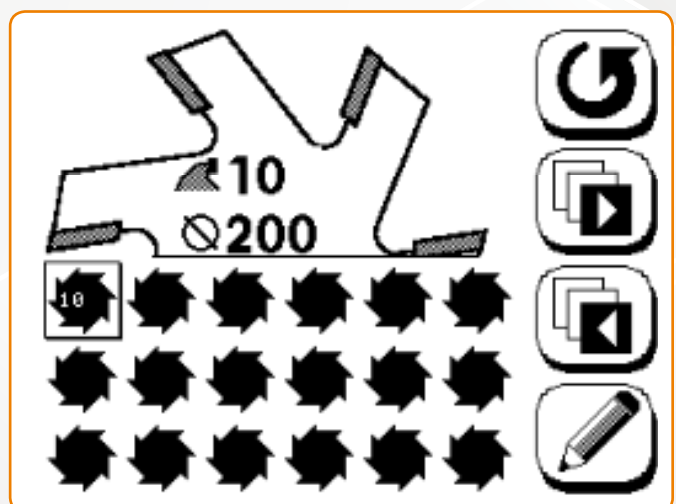

# ASP-631, M version

## Description and application

The ASP-631 version M is an optional extension for the machines in the F and PF versions, in the form of a third numerically controlled axis, which enables the sharpening of cutters for vee joints at the tooth face, by using a transverse support on which to mount the dividing head with the sharpened tool. You can also pre-set an additional angular incremental feed rate (if necessary). The machine is numerically controlled in three axes and has a very clear and user friendly programming system.

## Advantages

- 3 controlled axes
- Internal memory for saving cutter parameters
- Electronically controlled tooth pitch
- Robust and compact design
- Sharpening circular saws (optionally)
- Selecting the tool sharpening programme with or without moving the tool away from the grinding wheel during travel
- Controller functions to customise the parameters to individual user requirementscontroller's

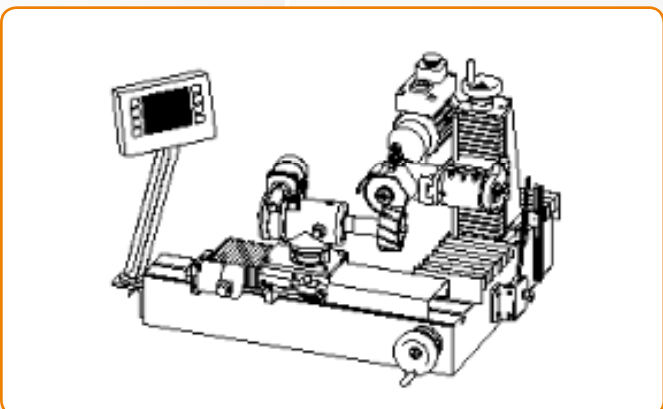

# TECHNICAL DATA

External diameter of the sharpened saw	100-630 mm (optionally 800 mm)
Diameter of the sharpened cutter	Up to 250 mm
Incremental feed rate during sharpening	0-0,99 mm
The number of programmable sharpening passes	0-99
The speed of grinding	0,2-2 m/min
Angle of inclination of the grinding wheel	$\pm 45^\circ$
Grinding wheel diameter	125 mm
Fixing hole diameter	20 mm
Installed power	2 kW
Coolant tank capacity	Approx. 40 litres
Weight	Approx. 495 – 660 kg
Dimensions	1540x1700x1800 mm

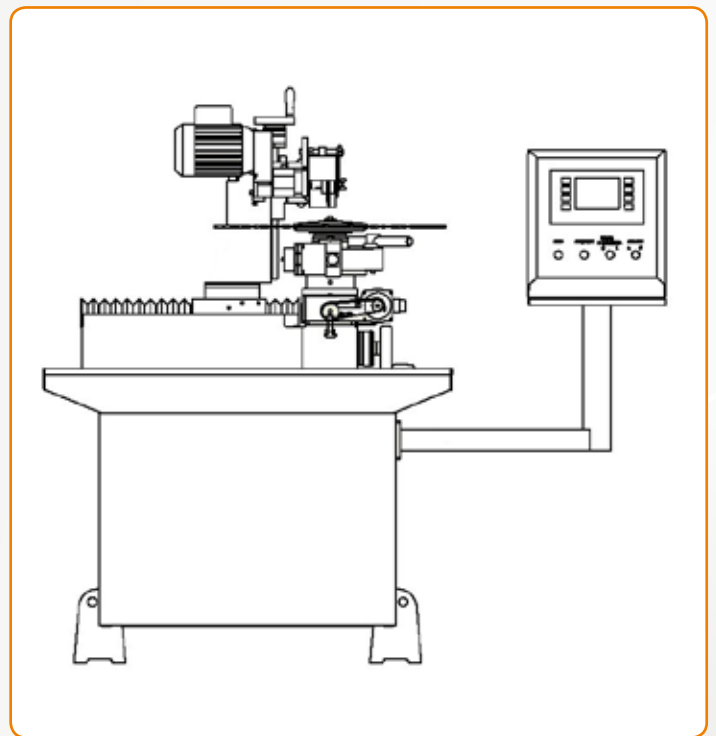
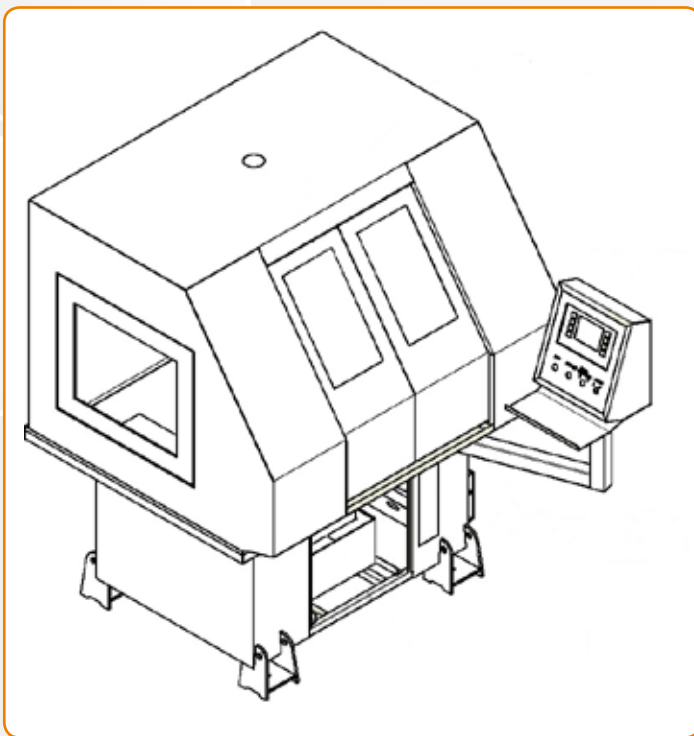

## Standard Components

- A stand
- A set of reduction rings
- An arbour for arbour type milling cutters
- Supporting disks
- A set of wrenches
- A starting package (grinding wheel and coolant)

## Accessories

- Cooling system
- A booth
- Attachment with tailstock
- Reduction sleeves with mounting
- An additional support and pressure disks
- An attachment for sharpening saws with a chip breaker
- An attachment for sharpening saws with a concave face

# Technologia ostrzenia



# Grinding Technology



ul. Główna 1, 58-530 Kowary

tel. +48 75 718 22 42

tel. +48 75 718 23 54

fax. +48 75 718 24 74

e-mail: [lakfam@lakfam.pl](mailto:lakfam@lakfam.pl)

[www.lakfam.pl](http://www.lakfam.pl)