



The grinder with a rotary head for sharpening the face and back of circular saw teeth, with the automatic measurement of tooth pitch (**N version**)



# ASP-631 WL / WLN

## Features of the ASP-631 WL/WLN

- Four numerically controlled axes
- Grinding of the top and face of most currently available tooth geometries in one cycle, without having to manually change the tool position and the wheelhead
- An intuitive and clear control system with a graphical user interface
- Sharpening saws with regular and irregular tooth pitches
- Minimum machine operating costs
- Robust and well thought-out design
- Electronically controlled tooth pitch
- High precision, maintenance-free dividing head.

## Outcome

- The perfect combination of precision and performance
- The highest price/quality ratio.



# Design Assumptions

The machines of the WL series are designed for automatic sharpening of circular saws with diameters ranging from 100 mm to 630 mm (optionally 800 mm).

- The rotary wheelhead enables the sharpening of trapezoidal teeth, alternate bevel teeth during a single sharpening cycle
- Tooth pitch measurement with the installed Renishaw probe (N version)
- Four numerically controlled axes enable the complete grinding of all available teeth shapes used in the woodworking industry
- Robust and compact design
- Adjusting the rake and clearance angles from the controller
- No hydraulic systems
- Using highest quality components
- Manufactured in Poland
- Electronically controlled tooth pitch
- No need to retool the dividing head manually, i.e. changing the pusher or other mechanical parts

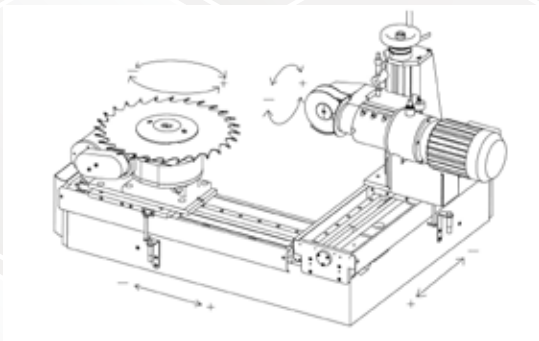

## Well thought-out design

Four numerically controlled axes

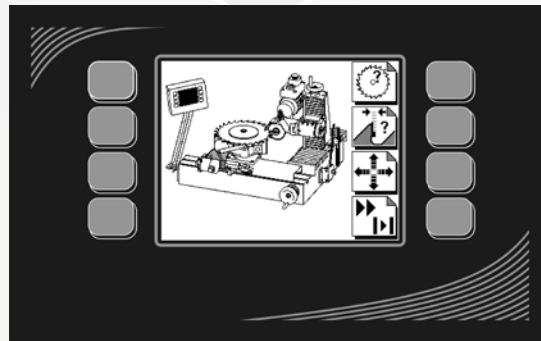

## Intuitive control system



## Sharpening the clearance surface



## The Renishaw probe for precise tooth measurement



## High-end components



## Sharpening of the tooth face

# Description and application

Polish engineering solutions have resulted in the creation of the functional and economical WL series grinders, which are an obvious choice for carpentry workshops, sawmills, furniture companies, and plants specialising in sharpening circular saws.

The use of 4 numerically controlled enables the sharpening of alternate bevel, trapezoidal teeth. In addition, the N version is equipped with the Renishaw precision probe to measure tooth pitch.

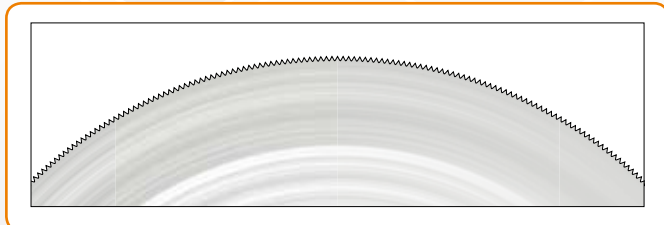
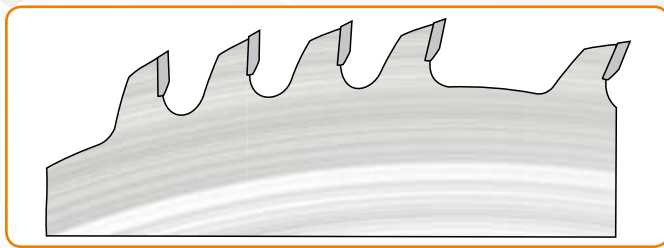
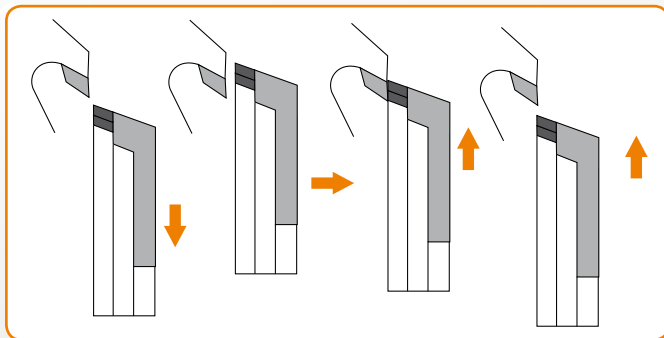
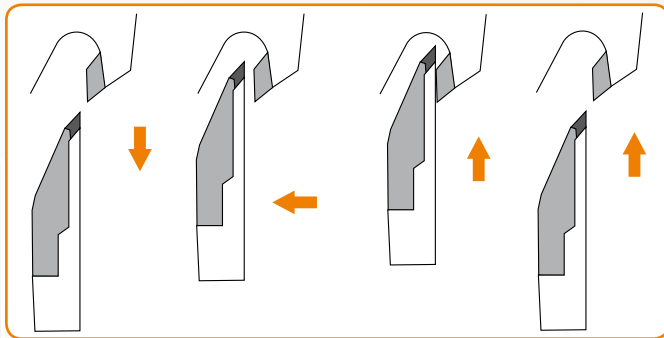

# Advantages

- 4 numerically controlled axes
- Electronically controlled tooth pitch
- Robust and compact design
- Programmable variable sharpening speeds
- Internal memory for saving saw parameters
- Sharpening saws with irregular (N version) and regular tooth pitches
- Sharpens the majority of currently used tooth geometries
- Multi-saw and scraper blade sharpening as standard
- An intuitive control system for programming the necessary tool and operating parameters
- Programmable tooth combinations
- Using of support and pressure disks to stabilise the saw
- Using the Renishaw probe (N version)
- A self-aligning head for sharpening the back of the tooth in a single sharpening pass
- Using highest quality components
- Skipping broken teeth
- Fully enclosed design

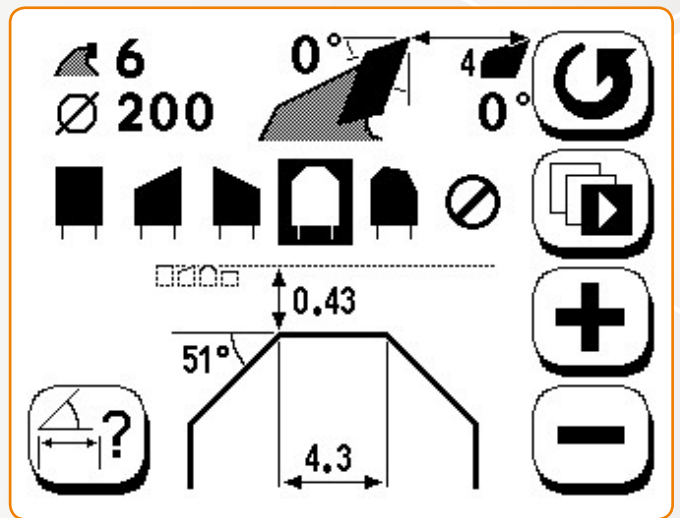
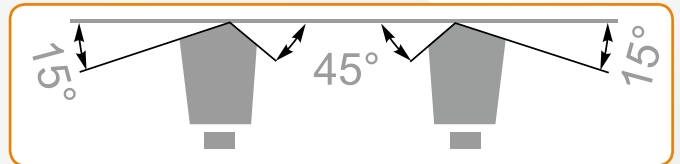

# TECHNICAL DATA

External diameter of the sharpened saw	100-630 mm (optionally 800 mm)
The number of sharpened teeth	3 - 999
Incremental feed rate during sharpening	0 - 0,99 mm
The number of programmable sharpening passes	0 - 99
The speed of grinding	0,2 - 2 m/min
Rake angle	-10° do +30°
Clearance angle	+5° do +45°
Grinding wheel diameter	150 mm
Fixing hole diameter	40 mm
Installed power	2 kW
Coolant tank capacity	Approx. 40 litres
Weight	Approx. 520 kg
Dimensions	1540x1700x1800 mm

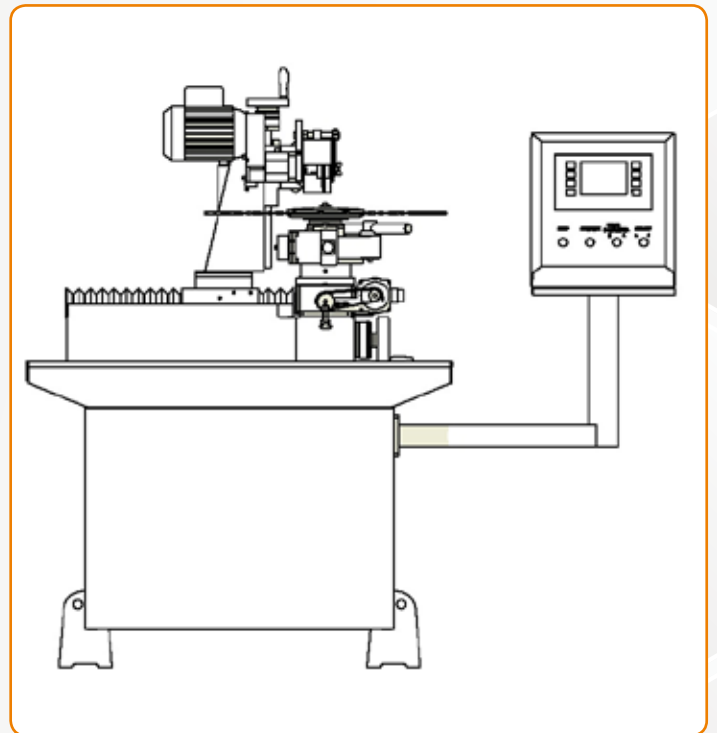
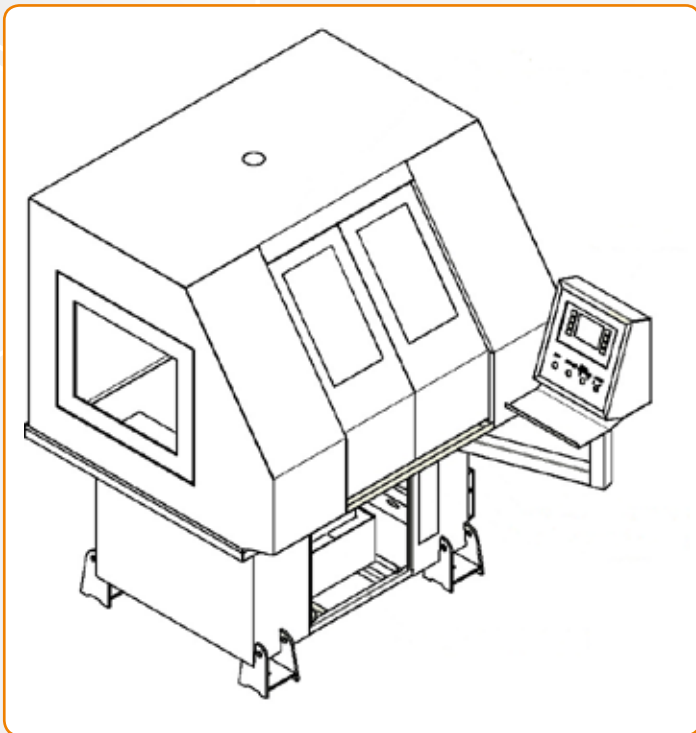

## Standard Components

- Full enclosure
- Cooling system
- A set of reduction rings
- Supporting disks
- A set of wrenches
- A starting package (grinding wheel and coolant)



# Technologia ostrzenia



# Grinding Technology



ul. Główna 1, 58-530 Kowary

tel. +48 75 718 22 42

tel. +48 75 718 23 54

fax. +48 75 718 24 74

e-mail: [lakfam@lakfam.pl](mailto:lakfam@lakfam.pl)

[www.lakfam.pl](http://www.lakfam.pl)